TRSL-3150WG / TRSL-3150AWG / TRSL-3150CWG / TRSL-3150ACWG (RoHS Compliant)
155 Mbps / 1310 nm / 3.3V SFF LC 2X10 SINGLE-MODE TRANSCEIVER

FEATURES

- Duplex LC Single Mode Transceiver
- SONET OC-3 LR-1 / SDH STM-1 (L-1.1) Compliant
- Small Form Factor, RJ-45 size, 2X10 pin Package
- 1310 nm LD Transmitter
- 29 dB Link Power Budget at Least
- Distance up to 50 km
- Analog Monitor Function
 - Transmitter Laser Bias Current
 - Transmitter Laser Optical Power Monitor
 - Receiver Photo Detector Current
- LVPECL Signal Input / Output
- LVTTL Transmitter Disable Input
- LVPECL Signal Detection Output: TRSL-3150WG
- LVTTL Signal Detection Output: TRSL-3150CWG
- Single +3.3 V Power Supply
- 0 to 70°C Operation: TRSL-3150WG
- -40 to 85°C Operation: TRSL-3150AWG
- Wave Solderable and Aqueous Washable
- Class 1 Laser International Safety Standard IEC-60825 Compliant

DESCRIPTION

The TRSL-3150WG series single mode transceivers are small form factor, low power, high performance module for bi-directional serial optical data communications such as SONET OC-3 LR-1 / SDH STM-1 (L-1.1) and Fast Ethernet. This module is designed for single mode fiber and operates at a nominal wavelength of 1310 nm. A guaranteed minimum optical link budget of 29 dB is offered which can correspond to a link distance of over 80 km (assuming worst case fiber loss of 0.4 dB/km). The transmitter section uses a multiple quantum well laser and is a class 1 laser compliant according to International Safety Standard IEC-60825. The receiver section uses an integrated InGaAs detector preamplifier (IDP) mounted in an optical header and a limiting post-amplifier IC. A PECL logic interface simplifies interface to external circuitry.

LASER SAFETY

This single mode transceiver is a Class 1 laser product. It complies with IEC-60825 and FDA 21 CFR 1040.10 and 1040.11. The transceiver must be operated within the specified temperature and voltage limits. The optical ports of the module shall be terminated with an optical connector or with a dust plug.

APPLICATIONS

- ATM 155 Mbps Links
- SONET / SDH Equipment Interconnect
- Fast Ethernet 100 Mb/s Links

ORDER INFORMATION

| P/No. | Bit Rate (Mb/s) | SONET /SDH | Distance (km) | Wavelength (nm) | Package | Temp. (°C) | TX Power (dBm) | RX Sens. (dBm) | RoHS Compliant |
|--------------|-----------------|------------|---------------|-----------------|---------|------------|----------------|----------------|----------------|
| TRSL-3150WG | 125 / 155 | LR-1/L-1.1 | 50 | 1310 | 2X10 LC | 0 to 70 | 0 to -5 | -34 | Yes |
| TRSL-3150AWG | 125 / 155 | LR-1/L-1.1 | 50 | 1310 | 2X10 LC | -40 to 85 | 0 to -5 | -34 | Yes |

Absolute Maximum Ratings

| Parameter | Symbol | Min | Max | Units | Notes |
|-----------------------|--------|-----|-----|-------|--------------------------|
| Storage Temperature | Tstg | -40 | 85 | °C | |
| Operating Temperature | Topr | 0 | 70 | °C | TRSL-3150WG |
| | | -40 | 85 | | TRSL-3150AWG |
| Soldering Temperature | --- | | 260 | °C | 10 seconds on leads only |
| Power Supply Voltage | Vcc | 0 | 4.5 | V | |
| Input Voltage | --- | GND | Vcc | V | |
| Output Current | Iout | 0 | 30 | mA | |

Recommended Operating Conditions

| Parameter | Symbol | Min | Typ | Max | Units / Notes |
|-----------------------|--------|------|-----------|------|-------------------|
| Power Supply Voltage | Vcc | 3.13 | 3.3 | 3.47 | V |
| Operating Temperature | Topr | 0 | | 70 | °C / TRSL-3150WG |
| | | -40 | | 85 | °C / TRSL-3150AWG |
| Data Rate | | | 125 / 155 | 200 | Mb/s |
| Power Supply Current | Icc | | 200 | 280 | mA |

| Transmitter Specifications (0°C < Topr < 70°C, 3.13V < Vcc < 3.47V) | | | | | | |
|---|--|-----------------------|------|-----------------|---------|--------------------|
| Parameter | Symbol | Min | Typ | Max | Units | Notes |
| Optical | | | | | | |
| Optical Transmit Power | Po | -5 | --- | 0 | dBm | 1 |
| Output Center Wavelength | λ | 1270 | 1310 | 1350 | nm | |
| Output Spectrum Width | $\Delta\lambda$ | --- | --- | 3 | nm | RMS(σ) |
| Extinction Ratio | ER | 10 | --- | --- | dB | |
| Output Eye | Compliant with Bellcore GR-253-CORE and ITU recommendation G.957 | | | | | |
| Optical Rise Time | t_r | | | 2 | ns | 10% to 90% Values |
| Optical Fall Time | t_f | | | 2 | ns | 10% to 90% Values |
| Relative Intensity Noise | RIN | | | -116 | dB/Hz | |
| Total Jitter | TJ | | | 1 | ns | 2 |
| Electrical | | | | | | |
| Data Input Current – Low | I _{IL} | -350 | | | μ A | |
| Data Input Current – High | I _{IH} | | | 350 | μ A | |
| Differential Input Voltage | V _{IH} - V _{IL} | 300 | | | mV | |
| Data Input Voltage – Low | V _{IL} - V _{CC} | -2.0 | | -1.58 | V | 3 |
| Data Input Voltage -- High | V _{IH} - V _{CC} | -1.1 | | -0.74 | V | 3 |
| Disable Input Voltage -- Low | V _{TDISL} | 0 | | 0.5 | V | TX Output Enabled |
| Disable Input Voltage -- High | V _{TDISH} | V _{CC} - 1.3 | | V _{CC} | V | TX Output Disabled |
| Shut Off Time for TxDis | t _{DIS} | | | 1 | ms | |

- Notes: 1. Output power is power coupled into a 9/125 μ m single mode fiber.
 2. Measured with 2²³-1 PRBS with 72 ones and 72 zeros
 3. These inputs are compatible with 10K, 10KH and 100K ECL and PECL inputs.

| Receiver Specifications (0°C < Topr < 70°C, 3.13V < Vcc < 3.47V) | | | | | | |
|--|-----------------------------------|------|-----|-------|-------|-------------------------|
| Parameter | Symbol | Min | Typ | Max | Units | Notes |
| Optical | | | | | | |
| Sensitivity | --- | --- | --- | -34 | dBm | 1 |
| Maximum Input Power | P _{in} | -3 | | --- | dBm | |
| Signal Detect -- Asserted | P _a | --- | --- | -34 | dBm | Transition: low to high |
| Signal Detect -- Deasserted | P _d | -47 | --- | --- | dBm | Transition: high to low |
| Signal detect -- Hysteresis | | 1.0 | --- | | dB | |
| Wavelength of Operation | | 1100 | --- | 1600 | nm | |
| Electrical | | | | | | |
| Data Output Voltage – Low | V _{OL} - V _{CC} | -2.0 | | -1.58 | V | 2 |
| Data Output Voltage – High | V _{OH} - V _{CC} | -1.1 | | -0.74 | V | 2 |
| Signal Detect Output Voltage -- Low | V _{OL} | | | 0.5 | V | TRSL-3150WG |
| Signal Detect Output Voltage -- High | V _{OH} | 2.0 | | | V | |
| Signal Detect Output Voltage -- Low | V _{OL} - V _{CC} | | | 0.5 | V | TRSL-3150CWG |
| Signal Detect Output Voltage -- High | V _{OH} - V _{CC} | 2.0 | | | V | |

- Notes: 1. Minimum sensitivity and saturation levels at BER=1E-10 for a 2²³-1 PRBS with 72 ones and 72 zeros.
 2. These outputs are compatible with 10K, 10KH and 100K ECL and PECL outputs.

ANALOG DIAGNOSTICS FUNCTIONS

| Parameter | Symbol | Min | Typ | Max | Units | Notes |
|------------------------------------|-----------------|-----|-----|-----------------|-------|-------|
| Transmitter | | | | | | |
| Laser Bias Current Monitor | Bmon+, Bmon- | 0 | | V _{CC} | V | 1 |
| Monitor Photodiode Current Monitor | Pmon+, Pmon- | 0 | | V _{CC} | V | 2 |
| Receiver | | | | | | |
| Received Photocurrent | R _{pd} | 0 | | 1 | mA | 3 |
| Photodiode Responsivity | R | 0.5 | 0.9 | 1.0 | A/W | |

| | | | | | | |
|-----------------------------|-----|-----|--|-----|---|---|
| Applied Voltage at VpdR pin | Vpd | 2.4 | | Vcc | V | 3 |
|-----------------------------|-----|-----|--|-----|---|---|

- Notes:
- PIN 17 and 18 provide an analog voltage output proportional to the laser bias current, based on the following formula: $I_{bias} = V (B_{mon+} - B_{mon-}) / 10 \Omega$. See below the equivalent circuit.
 - PIN 19 and 20 provide an analog voltage output proportional to the monitor photodiode current, based on the following formula: $I_{mon} = V (P_{mon+} - P_{mon-}) / 200 \Omega$. See below the equivalent circuit.
 - PIN 1 is used to monitor the received photocurrent. It must be connected to a positive voltage within the specified above. The received power is given by the photocurrent multiplied by the photodiode responsivity.

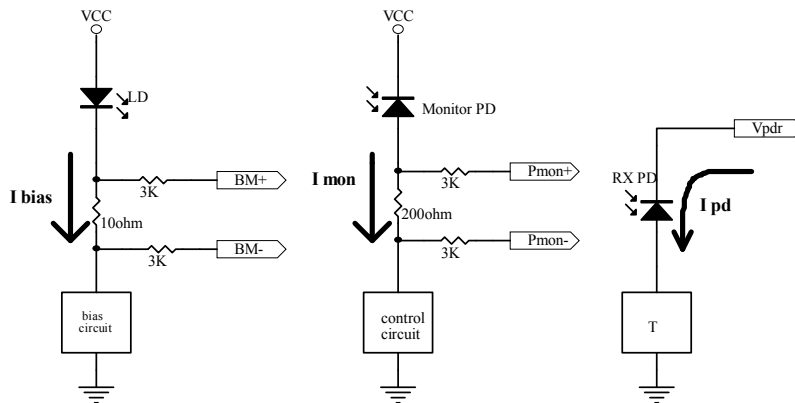

Analog Monitoring Function Connections

CONNECTION DIAGRAM

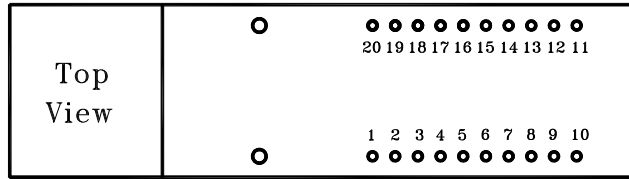

| PIN | Symbol | Notes | PIN | Symbol | Notes |
|-----|--------|---|-----|--------|---|
| 1 | VpdR | Receiver power monitor. This pin must be connected to a positive power supply (Vcc), preferably via a small resistor. Supplier photocurrent and maybe used to monitor receiver power. | 11 | VccT | +3.3V dc transmitter power supply |
| 2 | VeeR | Receiver ground. | 12 | VeeT | Transmitter ground. |
| 3 | VeeR | Receiver ground. | 13 | T Dis | Transmitter Disable. Connect this pin to logic "1" to disable module. To enable module connect to logic low "0" |
| 4 | NC | No connected | 14 | TD + | Transmitter Data In |
| 5 | NC | No connected | 15 | TD - | Transmitter Data In Bar |
| 6 | VeeR | Receiver ground. | 16 | VeeT | Transmitter ground. |
| 7 | VccR | +3.3V dc receiver power supply | 17 | Bmon- | Laser Bias Monitoring - Negative End |
| 8 | SD | Signal detect. Logic 1 indicate a normal operation. | 18 | Bmon+ | Laser Bias Monitoring - Positive End (Bmon+ - Bmon-) = 10 Ω X laser bias current |
| 9 | RD- | Receiver Dataout Bar | 19 | Pmon- | Laser Power Monitoring -- Negative end |
| 10 | RD+ | Receiver Dataout | 20 | Pmon+ | Laser Power Monitoring -- Positive end (Pmon+ - Pmon-) = 200 Ω X monitor photodiode current |
| MS | MS | Mounting Studs. Connect to Chassis Ground | | | |

RECOMMENDED CIRCUIT SCHEMATIC

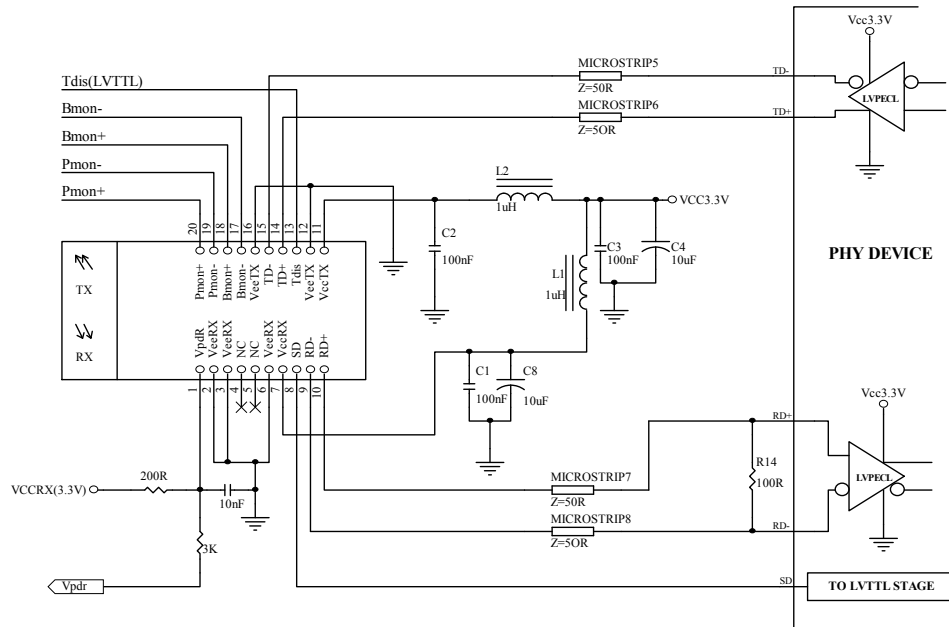

PACKAGE DIAGRAM

Units in mm

1) Standard Case

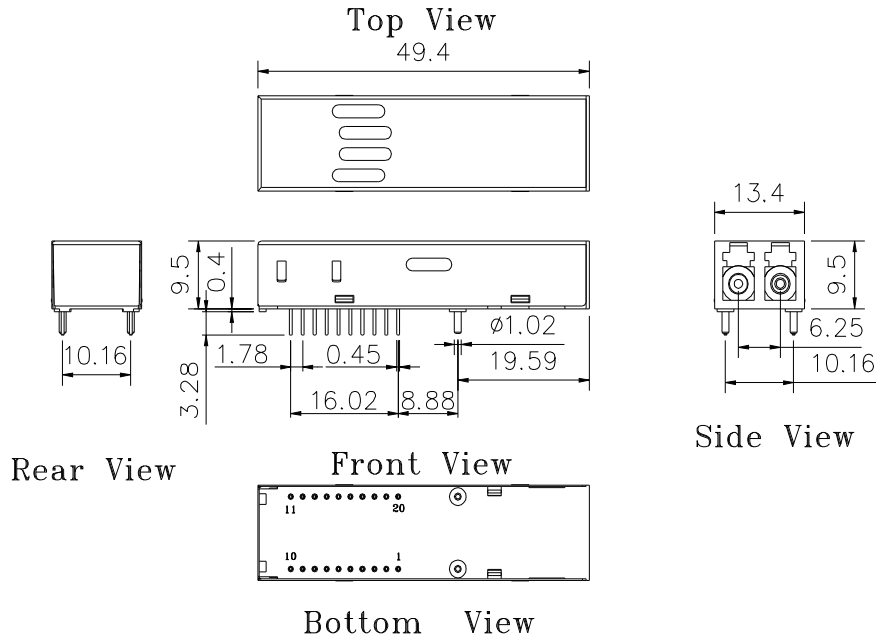

TRSL-3150WG / TRSL-3150AWG / TRSL-3150CWG / TRSL-3150ACWG

2) Extended Case

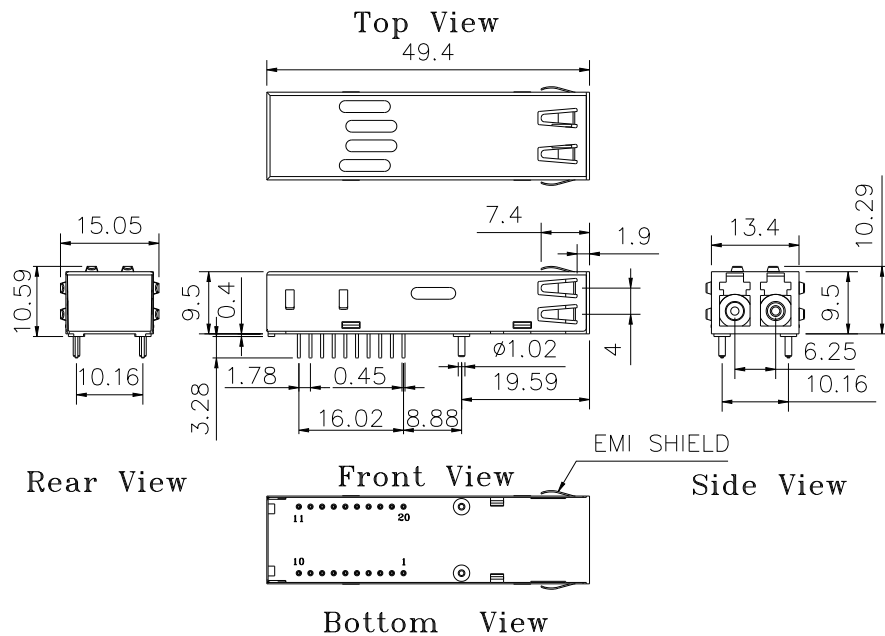

TRSL-3150WEG / TRSL-3150AWEG / TRSL-3150CWEG / TRSL-3150ACWEG

Note: Specifications subject to change without notice.

REVISION HISTORY

| Version | Subject | Release Date |
|---------|--|--------------|
| 2.0 | Initial datasheet | 2005/12/1 |
| 2.1 | Remove Note from the RECOMMENDED CIRCUIT SCHEMATIC | 2026/5/8 |
| | | |
| | | |