

TRSL-33120WG / TRSL-33120CWG

(RoHS Compliant)

155 Mbps / 1550 nm / 3.3V SFF LC 2X10 SINGLE-MODE TRANSCEIVER

FEATURES

- Duplex LC Single Mode Transceiver
- SONET OC-3 LR-2 / SDH STM-1 (L-1.2) Compliant
- Small Form Factor, RJ-45 size, 2X10 pin Package
- 1550 nm DFB LD Transmitter
- 34 dB Link Budget at Least
- Distance up to 120 km
- Analog Monitor Function
 - Transmitter Laser Bias Current
 - Transmitter Laser Optical Power Monitor
 - Receiver Photo Detector Current
- LVPECL Signal Input / Output
- LVTTTL Transmitter Disable Input
- LVPECL Signal Detection Output: TRSL-33120WG
- LVTTTL Signal Detection Output: TRSL-33120CWG
- Single +3.3 V Power Supply
- 0 to 70°C Operating
- Wave Solderable and Aqueous Washable
- Class 1 Laser International Safety Standard IEC-60825 Compliant

DESCRIPTION

The TRSL-33120WG series single mode transceivers are small form factor, low power, high performance module for bi-directional serial optical data communications such as SONET OC-3 LR-2 / SDH STM-1 (L-1.2) and Fast Ethernet. This module is designed for single mode fiber and operates at a nominal wavelength of 1550 nm. A guaranteed minimum optical link budget of 34 dB is offered which can correspond to a link distance of over 120 km (assuming worst case fiber loss of 0.25 dB/km). The transmitter section uses a multiple quantum well laser and is a class 1 laser compliant according to International Safety Standard IEC-60825. The receiver section uses an integrated InGaAs detector preamplifier (IDP) mounted in an optical header and a limiting post-amplifier IC. A PECL logic interface simplifies interface to external circuitry.

LASER SAFETY

This single mode transceiver is a Class 1 laser product. It complies with IEC-60825 and FDA 21 CFR 1040.10 and 1040.11. The transceiver must be operated within the specified temperature and voltage limits. The optical ports of the module shall be terminated with an optical connector or with a dust plug.

APPLICATIONS

- ATM 155 Mbps Links
- SONET / SDH Equipment Interconnect
- Fast Ethernet 100 Mb/s Links

ORDER INFORMATION

P/No.	Bit Rate (Mb/s)	SONET /SDH	Distance (km)	Wavelength (nm)	Package	Temp. (°C)	TX Power (dBm)	RX Sens. (dBm)	RoHS Compliant
TRSL-33120WG	125 / 155		120	1550 DFB	2X10 LC	0 to 70	5 to 0	-34	Yes

Absolute Maximum Ratings					
Parameter	Symbol	Min	Max	Units	Notes
Storage Temperature	Tstg	-40	85	°C	
Operating Temperature	Topr	0	70	°C	With air flow 1m/sec
Soldering Temperature	---		260	°C	10 seconds on leads only
Power Supply Voltage	Vcc	0	4.5	V	
Input Voltage	---	GND	Vcc	V	
Output Current	Iout	0	30	mA	

Recommended Operating Conditions					
Parameter	Symbol	Min	Typ	Max	Units / Notes
Power Supply Voltage	Vcc	3.13	3.3	3.47	V
Operating Temperature	Topr	0		70	°C / air flow 1m/sec
Data Rate			125 / 155	200	Mb/s
Power Supply Current	Icc			280	mA

Transmitter Specifications (0°C < Topr < 70°C, 3.13V < Vcc < 3.47V)						
Parameter	Symbol	Min	Typ	Max	Units	Notes
Optical						
Optical Transmit Power	Po	0	---	5	dBm	1
Output Center Wavelength	λ	1480	1550	1580	nm	
Output Spectrum Width	$\Delta\lambda$	---	---	1	nm	-20 dB Width
Side Mode Suppression Ratio	SMSR	30			dB	
Extinction Ratio	ER	10	---	---	dB	
Output Eye	Compliant with Bellcore GR-253-CORE and ITU recommendation G.957					
Optical Rise Time	t_r			2	ns	10% to 90% Values
Optical Fall Time	t_f			2	ns	10% to 90% Values
Relative Intensity Noise	RIN			-116	dB/Hz	
Total Jitter	TJ			1	ns	2
Electrical						
Data Input Current – Low	I _{IL}	-350			μA	
Data Input Current – High	I _{IH}			350	μA	
Differential Input Voltage	V _{IH} - V _{IL}	300			mV	
Data Input Voltage – Low	V _{IL} - V _{CC}	-2.0		-1.58	V	3
Data Input Voltage -- High	V _{IH} - V _{CC}	-1.1		-0.74	V	3
Disable Input Voltage -- Low	V _{TDISL}	0		0.5	V	TX Output Enabled
Disable Input Voltage -- High	V _{TDISH}	V _{CC} - 1.3		V _{CC}	V	TX Output Disabled
Shut Off Time for TxDis	t _{DIS}			1	ms	

- Notes: 1. Output power is power coupled into a 9/125 μm single mode fiber.
 2. Measured with 2²³-1 PRBS with 72 ones and 72 zeros
 3. These inputs are compatible with 10K, 10KH and 100K ECL and PECL inputs.

Receiver Specifications (0°C < Topr < 70°C, 3.13V < Vcc < 3.47V)						
Parameter	Symbol	Min	Typ	Max	Units	Notes
Optical						
Sensitivity	---	---	---	-34	dBm	1
Maximum Input Power	Pin	-3		---	dBm	
Signal Detect -- Asserted	Pa	---	---	-34	dBm	Transition: low to high
Signal Detect -- Deasserted	Pd	-47	---	---	dBm	Transition: high to low
Signal detect -- Hysteresis		1.0	---		dB	
Wavelength of Operation		1100	---	1600	nm	
Electrical						
Data Output Voltage – Low	V _{OL} - V _{CC}	-2.0		-1.58	V	2
Data Output Voltage – High	V _{OH} - V _{CC}	-1.1		-0.74	V	2
Signal Detect Output Voltage -- Low	V _{OL} - V _{CC}	-2.0		-1.58		TRSL-33120WG
Signal Detect Output Voltage -- High	V _{OH} - V _{CC}	-1.1		-0.74		
Signal Detect Output Voltage -- Low	V _{OL}			0.5	V	TRSL-33120CWG
Signal Detect Output Voltage -- High	V _{OH}	2.0			V	

- Notes: 1. Minimum sensitivity and saturation levels at BER=1E-10 for a 2²³-1 PRBS with 72 ones and 72 zeros.
 2. These outputs are compatible with 10K, 10KH and 100K ECL and PECL outputs.

ANALOG DIAGNOSTICS FUNCTIONS

Parameter	Symbol	Min	Typ	Max	Units	Notes
Transmitter						
Laser Bias Current Monitor	Bmon+, Bmon-	0		Vcc	V	1
Monitor Photodiode Current Monitor	Pmon+, Pmon-	0		Vcc	V	2
Receiver						
Received Photocurrent	Rpd	0		I	mA	3
Photodiode Responsivity	R	0.5	0.9	1.0	A/W	
Applied Voltage at VpdR pin	Vpd	2.4		Vcc	V	3

- Notes: 1. PIN 17 and 18 provide an analog voltage output proportional to the laser bias current, based on the following formula: $I_{bias} = V (Bmon+ - Bmon-) / 10 \Omega$. See below the equivalent circuit.
2. PIN 19 and 20 provide an analog voltage output proportional to the monitor photodiode current, based on the following formula: $I_{mon} = V (Pmon+ - Pmon-) / 200 \Omega$. See below the equivalent circuit.
3. PIN 1 is used to monitor the received photocurrent. It must be connected to a positive voltage within the specified above. The received power is given by the photocurrent multiplied by the photodiode responsivity.

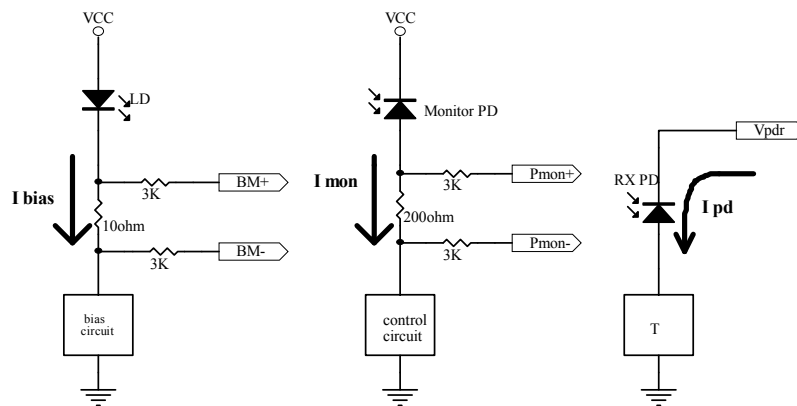

Analog Monitoring Function Connections

CONNECTION DIAGRAM

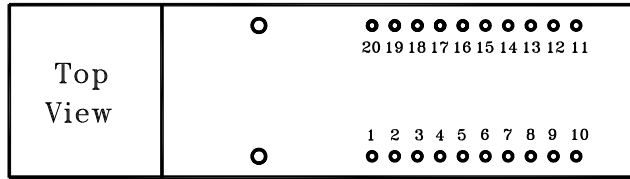

PIN	Symbol	Notes	PIN	Symbol	Notes
1	VpdR	Receiver power monitor. This pin must be connected to a positive power supply (Vcc), preferably via a small resistor. Supplier photocurrent and maybe used to monitor receiver power.	11	VccT	+3.3V dc transmitter power supply
2	VeeR	Receiver ground.	12	VeeT	Transmitter ground.
3	VeeR	Receiver ground.	13	T Dis	Transmitter Disable. Connect this pin to logic "1" to disable module. To enable module connect to logic low "0"
4	NC	No connected	14	TD +	Transmitter Data In
5	NC	No connected	15	TD -	Transmitter Data In Bar
6	VeeR	Receiver ground.	16	VeeT	Transmitter ground.
7	VccR	+3.3V dc receiver power supply	17	Bmon-	Laser Bias Monitoring - Negative End
8	SD	Signal detect. Logic 1 indicate a normal operation.	18	Bmon+	Laser Bias Monitoring - Positive End (Bmon+ - Bmon-) = 10 Ω X laser bias current
9	RD-	Receiver Dataout Bar	19	Pmon-	Laser Power Monitoring -- Negative end
10	RD+	Receiver Dataout	20	Pmon+	Laser Power Monitoring -- Positive end (Pmon+ - Pmon-) = 200 Ω X monitor photodiode current
MS	MS	Mounting Studs. Connect to Chassis Ground			

RECOMMENDED CIRCUIT SCHEMATIC

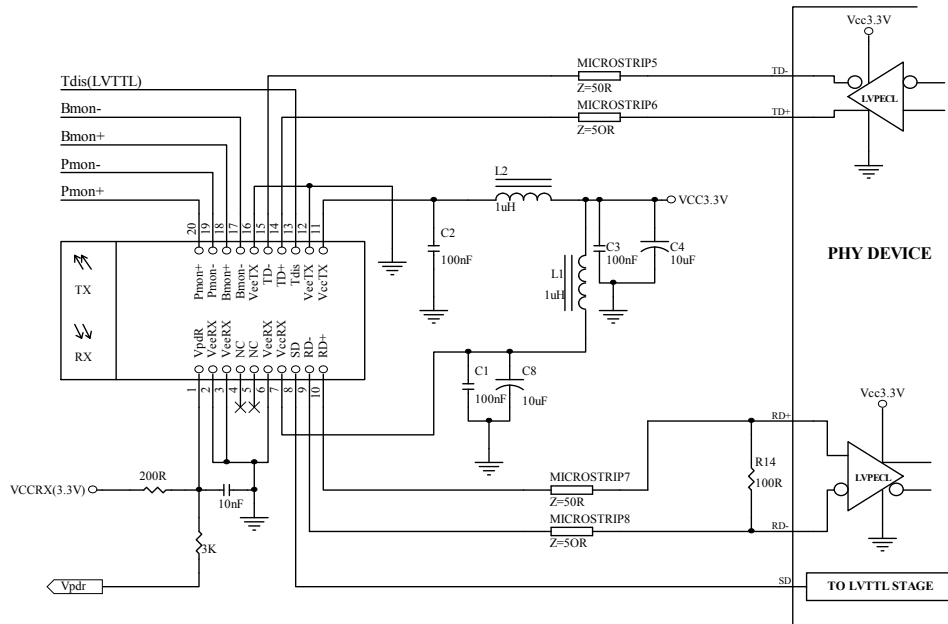

PACKAGE DIAGRAM

Units in mm

1) Standard Case

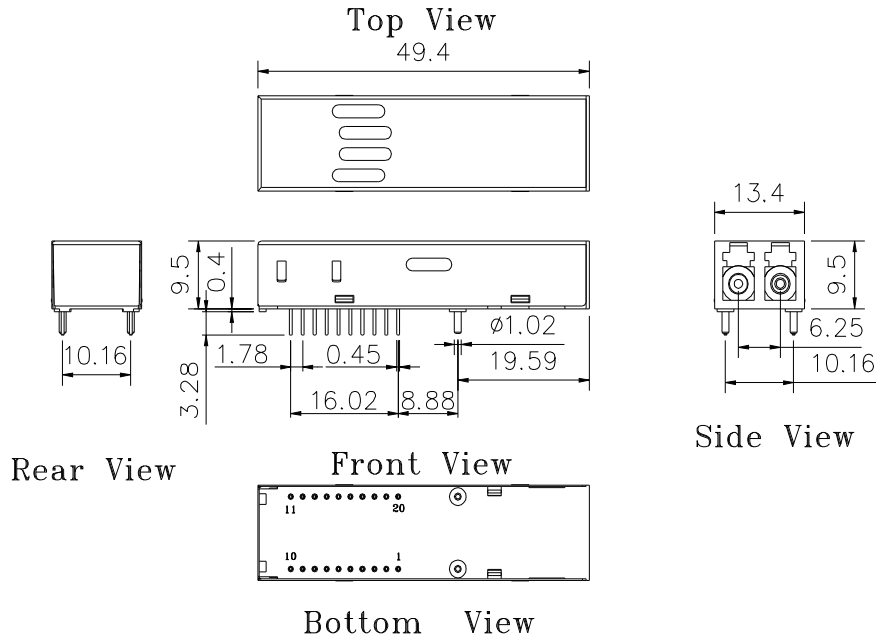

TRSL-33120WG / TRSL-33120CWG

2) Extended Case

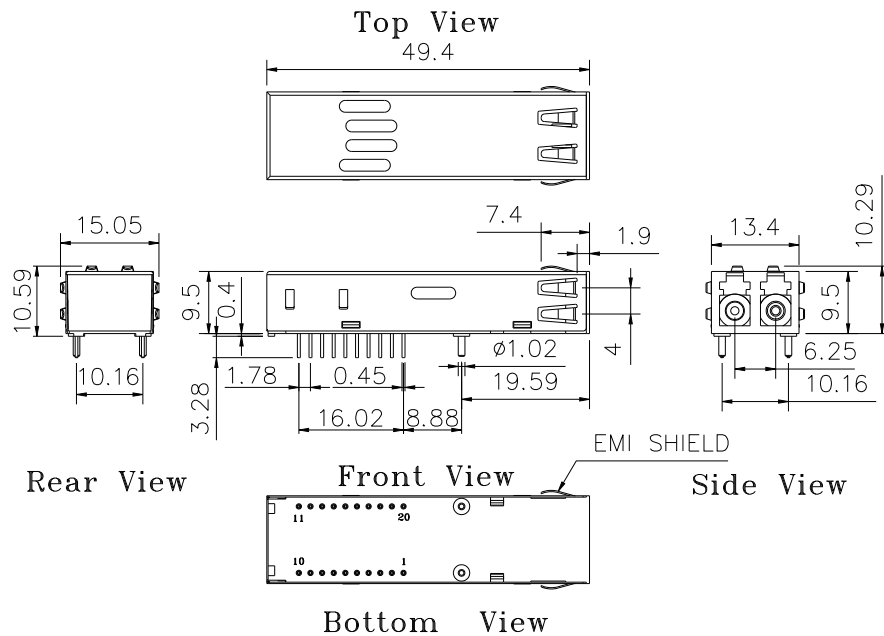

TRSL-33120WEG / TRSL-33120CWEG

Note: Specifications subject to change without notice.

REVISION HISTORY

Version	Subject	Release Date
2.0	Initial datasheet	2005/12/1
2.1	Remove Note from the RECOMMENDED CIRCUIT SCHEMATIC	2026/5/8