

### TRSL-5120G / TRSL-5120AG / TRSL-5120CG / TRSL-5120ACG

### 622 Mbps / 1310 nm / 3.3V RoHS Compliant SFF LC SINGLE-MODE TRANSCEIVER

#### FEATURES

- Duplex LC Single Mode Transceiver
- SONET OC-12 IR-1 / SDH STM-4 (S-4.1) Compliant
- Small Form Factor, RJ-45 size, 2X5 pin Package
- 1310 nm LD Transmitter
- LVPECL Signal Input / Output
- LVTTL Transmitter Disable Input
- LVPECL Signal Detection Output: TRSL-5120G
- LVTTL Signal Detection Output: TRSL-5120CG
- Single +3.3 V Power Supply
- RoHS Compliant
- 0 to 70°C Operation: TRSL-5120G
- -40 to 85°C Operation: TRSL-5120AG
- Wave Solderable and Aqueous Washable
- Class 1 Laser International Safety Standard IEC-60825 Compliant

#### APPLICATIONS

- ATM 622 Mbps Links
- SONET / SDH Equipment Interconnect
- Fiber Channel 533 Mb/s Links

#### DESCRIPTION

The TRSL-5120G series single mode transceivers are small form factor, low power, high performance module for bi-directional serial optical data communications such as SONET OC-12 IR-1 / SDH STM-4 (S-4.1) and Fiber Channel. This module is designed for single mode fiber and operates at a nominal wavelength of 1310 nm. The transmitter section uses a multiple quantum well laser and is a class 1 laser compliant according to International Safety Standard IEC-60825. The receiver section uses an integrated InGaAs detector preamplifier (IDP) mounted in an optical header and a limiting post-amplifier IC. A PECL logic interface simplifies interface to external circuitry.

#### LASER SAFETY

This single mode transceiver is a Class 1 laser product. It complies with IEC-60825 and FDA 21 CFR 1040.10 and 1040.11. The transceiver must be operated within the specified temperature and voltage limits. The optical ports of the module shall be terminated with an optical connector or with a dust plug.

#### ORDER INFORMATION

P/No.	Bit Rate (Mb/s)	SONET /SDH	Distance (km)	Wavelength (nm)	Package	Temp. (°C)	TX Power (dBm)	RX Sens. (dBm)	RoHS Compliant
TRSL-5120G	622	IR-1/S-4.1	20	1310	2X5 LC	0 to 70	-8 to -14	-28	Yes
TRSL-5120AG	622	IR-1/S-4.1	20	1310	2X5 LC	-40 to 85	-8 to -14	-28	Yes

#### Absolute Maximum Ratings

Parameter	Symbol	Min	Max	Units	Notes
Storage Temperature	Tstg	-40	85	°C	
Operating Temperature	Topr	0 -40	70 85	°C	TRSL-5120G TRSL-5120AG
Soldering Temperature	---		260	°C	10 seconds on leads only
Power Supply Voltage	Vcc	0	4.5	V	
Input Voltage	---	GND	Vcc	V	
Output Current	Iout	0	30	mA	

#### Recommended Operating Conditions

Parameter	Symbol	Min	Typ	Max	Units / Notes
Power Supply Voltage	Vcc	3.13	3.3	3.47	V
Operating Temperature	Topr	0 -40		70 85	°C / TRSL-5120G °C / TRSL-5120AG
Data Rate		50	622		Mb/s
Power Supply Current	Icc		180	240	mA

\*\*\*\*\*

Transmitter Specifications (0°C < Topr < 70°C, 3.13V < Vcc < 3.47V)						
Parameter	Symbol	Min	Typ	Max	Units	Notes
<b>Optical</b>						
Optical Transmit Power	Po	-14	---	-8	dBm	1
Output Center Wavelength	$\lambda$	1274	1310	1356	nm	
Output Spectrum Width	$\Delta\lambda$	---	---	2.5	nm	RMS( $\sigma$ )
Extinction Ratio	ER	8.2	---	---	dB	
Output Eye	Compliant with Bellcore GR-253-CORE and ITU recommendation G.957					
Optical Rise Time	$t_r$			1.2	ns	10% to 90% Values
Optical Fall Time	$t_f$			1.2	ns	10% to 90% Values
Relative Intensity Noise	RIN			-120	dB/Hz	
Total Jitter	TJ			0.55	ns	2
<b>Electrical</b>						
Data Input Current – Low	I <sub>IL</sub>	-350			$\mu$ A	
Data Input Current – High	I <sub>IH</sub>			350	$\mu$ A	
Differential Input Voltage	V <sub>IH</sub> - V <sub>IL</sub>	300			mV	
Data Input Voltage – Low	V <sub>IL</sub> - V <sub>CC</sub>	-2.0		-1.58	V	3
Data Input Voltage -- High	V <sub>IH</sub> - V <sub>CC</sub>	-1.1		-0.74	V	3
Disable Input Voltage -- Low	V <sub>TDISL</sub>	0		0.5	V	TX Output Enabled
Disable Input Voltage -- High	V <sub>TDISH</sub>	V <sub>CC</sub> - 1.3		V <sub>CC</sub>	V	TX Output Disabled
Shut Off Time for TxDis	t <sub>DIS</sub>			1	ms	

- Notes: 1. Output power is power coupled into a 9/125  $\mu$ m single mode fiber.  
 2. Measured with 2<sup>23</sup>-1 PRBS with 72 ones and 72 zeros  
 3. These inputs are compatible with 10K, 10KH and 100K ECL and PECL inputs.

Receiver Specifications (0°C < Topr < 70°C, 3.13V < Vcc < 3.47V)						
Parameter	Symbol	Min	Typ	Max	Units	Notes
<b>Optical</b>						
Sensitivity	---	---	---	-28	dBm	1
Maximum Input Power	P <sub>in</sub>	-5		---	dBm	
Signal Detect -- Asserted	P <sub>a</sub>	---	---	-28	dBm	Transition: low to high
Signal Detect -- Deasserted	P <sub>d</sub>	-40	---	---	dBm	Transition: high to low
Signal detect -- Hysteresis		1.0	---		dB	
Wavelength of Operation		1100	---	1600	nm	
<b>Electrical</b>						
Data Output Voltage – Low	V <sub>OL</sub> - V <sub>CC</sub>	-2.0		-1.58	V	2
Data Output Voltage – High	V <sub>OH</sub> - V <sub>CC</sub>	-1.1		-0.74	V	2
Signal Detect Output Voltage -- Low	V <sub>OL</sub>	-2.0		-1.58	V	TRSL-5120G
Signal Detect Output Voltage -- High	V <sub>OH</sub>	-1.1		-0.74	V	
Signal Detect Output Voltage -- Low	V <sub>OL</sub> - V <sub>CC</sub>			0.5	V	TRSL-5120CG
Signal Detect Output Voltage -- High	V <sub>OH</sub> - V <sub>CC</sub>	2.0			V	

- Notes: 1. Minimum sensitivity and saturation levels at BER=1E-10 for a 2<sup>23</sup>-1 PRBS with 72 ones and 72 zeros.  
 2. These outputs are compatible with 10K, 10KH and 100K ECL and PECL outputs.

\*\*\*\*\*

### CONNECTION DIAGRAM



PIN	Symbol	Notes
1	$V_{EEr}$	Directly connect this pin to the receiver ground plane
2	$V_{CCr}$	+3.3V dc power for the receiver section
3	SD	Active high on this indicates a received optical signal.
4	RD-	Receiver Data out Bar. See recommended circuit schematic
5	RD+	Receiver Data out. See recommended circuit schematic
6	$V_{CCt}$	+3.3V dc power for the transmitter section
7	$V_{EEt}$	Directly connect this pin to the transmitter ground plane
8	TDis	Transmitter Disable. Connect this pin to +3.3V TTL logic "1" to disable module To enable module connect to TTL logic low "0"
9	TD+	Transmitter Data In. See recommended circuit schematic
10	TD-	Transmitter Data In Bar. See recommended circuit schematic
MS	MS	Mounting Studs. Connect to Chassis Ground

### RECOMMENDED CIRCUIT SCHEMATIC

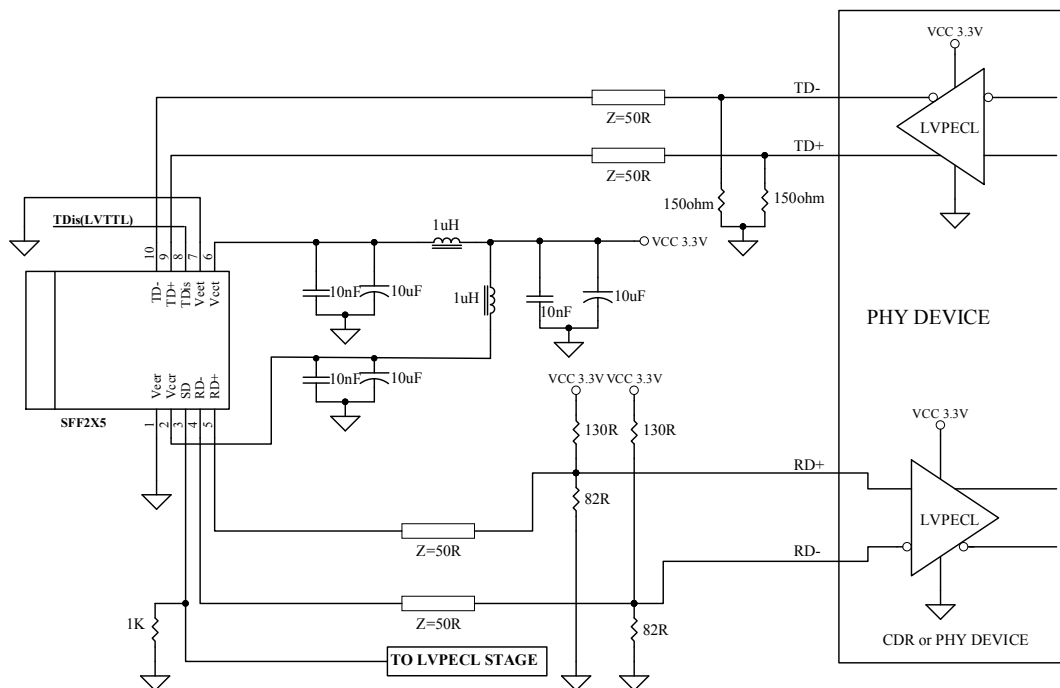

\*\*\*\*\*  
**PACKAGE DIAGRAM**

Units in mm

1) Standard Case

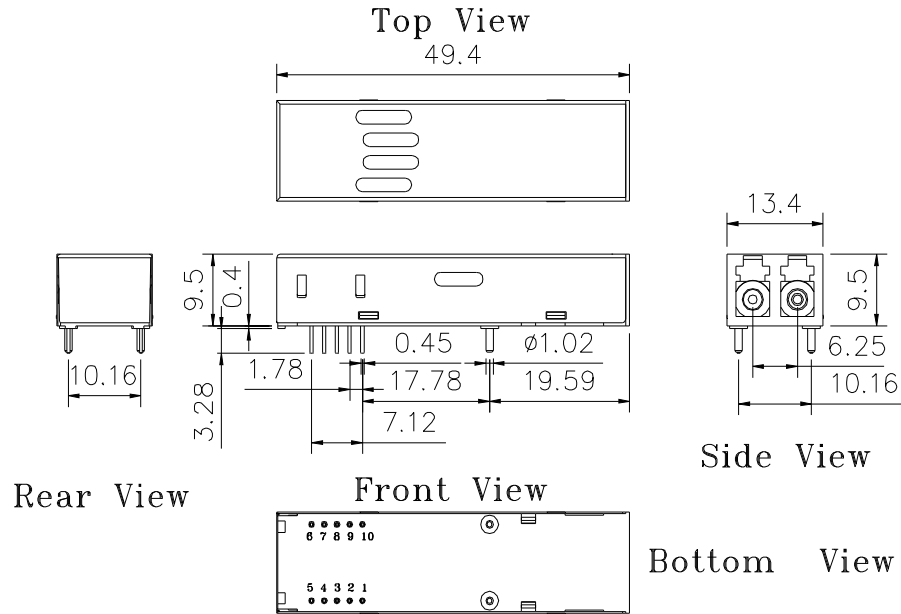

TRSL-5120G / TRSL-5120AG / TRSL-5120CG / TRSL-5120ACG

2) Extended Case

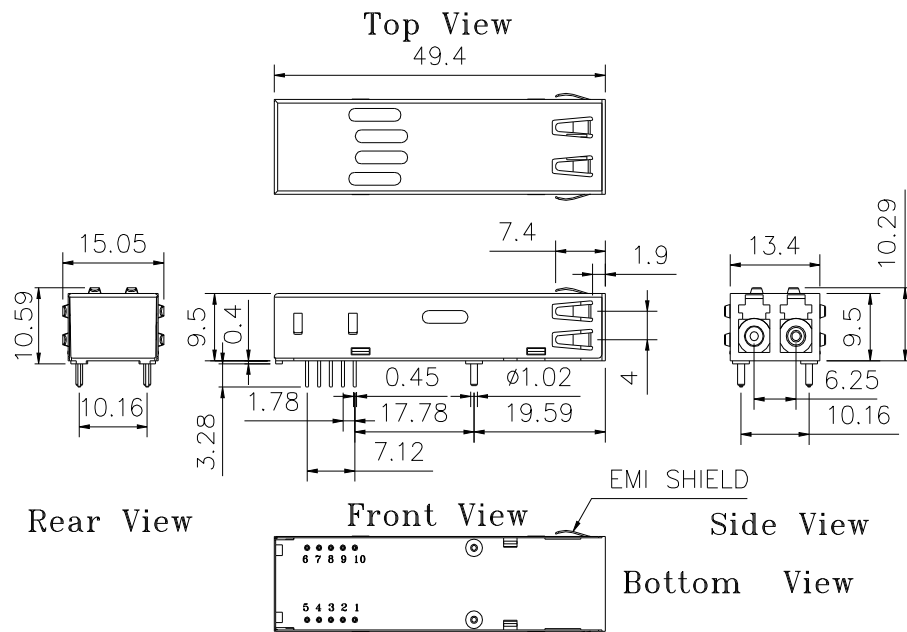

TRSL-5120EG / TRSL-5120AEG / TRSL-5120CEG / TRSL-5120ACEG

**Note:** Specifications subject to change without notice.

\*\*\*\*\*  
**REVISION HISTORY**

Version	Subject	Release Date
2.0	Initial datasheet	2005/12/1
2.1	Remove Note from the RECOMMENDED CIRCUIT SCHEMATIC	2026/5/8