

### TRSL-9115WG / TRSL-9115AWG

(RoHS Compliant)

### 2.5 Gbps / 15 km / 1310 nm / SFF LC 2X10 SINGLE-MODE TRANSCEIVER

#### FEATURES

- Duplex LC Single Mode Transceiver
- SONET OC-48 IR / SDH STM-16 (S-16.1) Compliant
- Compliant with Fiber Channel 2X/1X SM-LC-L FC-PI
- Compliant with IEEE 802.3z Gigabit Ethernet
- Multi-sourced 2X10 SFF Package Style
- 1310 nm DFB LD Transmitter
- 13 dB Link Power Budget At Least
- Analog Monitor Function
  - Transmitter Laser Bias Current
  - Transmitter Laser Optical Power Monitor
  - Receiver Photo Detector Current
- AC/AC Coupled Signal Input / Output
- LVPECL Signal Input / Output
- LVTTTL Signal Detection Output
- Single +3.3 V Power Supply
- RoHS Compliant
- 0 to 70°C Operation: TRSL-9115WG
- -40 to 85°C Operation: TRSL-9115AWG
- Wave Solderable
- Class 1 Laser International Safety Standard IEC-60825 Compliant

#### DESCRIPTION

The TRSL-9115WG series single mode transceivers is small form factor, low power, high performance module for bi-directional serial optical data communications such as SONET OC-48 IR / SDH STM-16 (S-16.1), IEEE 802.3z Gigabit Ethernet and 1X/2X Fiber channel. This module is designed for single mode fiber and operates at a nominal wavelength of 1310 nm. The transmitter section uses a multiple quantum well 1310 nm DFB laser and is a class 1 laser compliant according to International Safety Standard IEC-60825. The receiver section uses an integrated InGaAs detector preamplifier (IDP) mounted in an optical header and a limiting post-amplifier IC. A LVPECL logic interface simplifies interface to external circuitry.

#### LASER SAFETY

This single mode transceiver is a Class 1 laser product. It complies with IEC-60825 and FDA 21 CFR 1040.10 and 1040.11. The transceiver must be operated within the specified temperature and voltage limits. The optical ports of the module shall be terminated with an optical connector or with a dust plug

#### APPLICATIONS

- ATM Switches and Routers
- SONET / SDH Switch Infrastructure
- XDSL Applications

#### ORDER INFORMATION

P/No.	Bit Rate (Mb/s)	SONET /SDH	Distance (km)	Wavelength (nm)	Package	Temp. (°C)	TX Power (dBm)	RX Sens. (dBm)	RoHS Compliant
TRSL-9115WG	2488	IR-1/S-16.1	15	1310 DFB	2X10 LC	0 to 70	0 to -5	-18	Yes
TRSL-9115AWG	2488	IR-1/S-16.1	15	1310 DFB	2X10 LC	-40 to 85	0 to -5	-18	Yes

#### Absolute Maximum Ratings

Parameter	Symbol	Min	Max	Units	Notes
Storage Temperature	Tstg	-40	85	°C	
Operating Temperature	Topr	0	70	°C	TRSL-9115WG
		-40	85		TRSL-9115AWG
Soldering Temperature	---		260	°C	10 seconds on leads only
Power Supply Voltage	Vcc	-0.5	3.6	V	
Input Voltage	---	-0.5	Vcc	V	
Output Current	Iout	0	50	mA	

#### Recommended Operating Conditions

Parameter	Symbol	Min	Typ	Max	Units / Notes
Power Supply Voltage	Vcc	3.13	3.3	3.47	V
Operating Temperature	Topr	0		70	°C / TRSL-9115WG
		-40		85	°C / TRSL-9115AWG
					air flow 1m/sec
Data Rate		622	2500	2700	Mb/s

\*\*\*\*\*

Transmitter Specifications (0°C < Topr < 70°C, 3.13V < Vcc < 3.47V)						
Parameter	Symbol	Min	Typ	Max	Units	Notes
<b>Optical</b>						
Optical Transmit Power	Po	-5	---	0	dBm	1
Output Center Wavelength	$\lambda$	1280	1310	1335	nm	
Output Spectrum Width	$\Delta\lambda$	---	---	1	nm	-20 dB Width
Side Mode Suppression Ratio	SMSR	30			dB	
Extinction Ratio	ER	8.2	---	---	dB	
Output Eye	Compliant with Bellcore GR-253-GORE and ITU-T Recommendation G.957					
Optical Rise Time	tr			150	ps	20% to 80% Values
Optical Fall Time	tf			150	ps	20% to 80% Values
Relative Intensity Noise	RIN			-120	dB/Hz	
<b>Electrical</b>						
Power Supply Current	Icc			180	mA	2
Data Input Current – Low	IIL	-350			$\mu$ A	
Data Input Current – High	IiH			350	$\mu$ A	
Differential Input Voltage	V <sub>IH</sub> - V <sub>IL</sub>	300		1600	mV	
Data Input Voltage – Low	V <sub>IL</sub> - V <sub>CC</sub>	-2.0		-1.58	V	3
Data Input Voltage -- High	V <sub>IH</sub> - V <sub>CC</sub>	-1.1		-0.74	V	3
TX Disable Input Voltage – Low	T <sub>DIS</sub>	0		0.5	V	
TX Disable Input Voltage – High	T <sub>DIS</sub>	2.0		Vcc	V	
TX Disable Assert Time	T <sub>ASSERT</sub>			10	$\mu$ s	
TX Disable Deassert Time	T <sub>DEASSERT</sub>			50	$\mu$ s	

- Notes: 1. Output power is power coupled into a 9/125  $\mu$ m single mode fiber.  
 2. Maximum current is specified at Vcc = Maximum @ maximum temperature.  
 3. These inputs are compatible with 10K, 10KH and 100K ECL and PECL inputs.

Receiver Specifications (0°C < Topr < 70°C, 3.13V < Vcc < 3.47V)						
Parameter	Symbol	Min	Typ	Max	Units	Notes
<b>Optical</b>						
Sensitivity @ 2.488 Gbps	Sen1	---		-18	dBm	1
Sensitivity @ 1.25 Gbps	Sen2			-20	dBm	2
Maximum Input Power	Pin	0		---	dBm	
Signal Detect -- Asserted	Pa	---	---	-18	dBm	Transition: low to high
Signal Detect -- Deasserted	Pd	-35	---	---	dBm	Transition: high to low
Signal Detect -- Hysteresis		1.0	---	4.0	dB	
Wavelength of Operation		1100	---	1600	nm	
<b>Electrical</b>						
Power Supply Current	Icc		110	140	mA	
Data Output Voltage – Low	V <sub>OL</sub> - V <sub>CC</sub>	-2.0		-1.58	V	3
Data Output Voltage – High	V <sub>OH</sub> - V <sub>CC</sub>	-1.1		-0.74	V	3
Signal Detect Output Voltage -- Low	V <sub>SDL</sub>	0		0.8	V	
Signal Detect Output Voltage -- High	V <sub>SDH</sub>	2.0		Vcc+0.3	V	

- Notes: 1. Minimum sensitivity and saturation levels at BER=1E-10 for a 2<sup>23</sup>-1 PRBS.  
 2. Minimum sensitivity and saturation levels at BER=1E-12 for a 2<sup>7</sup>-1 PRBS.  
 3. These outputs are compatible with 10K, 10KH and 100K ECL and PECL inputs.

\*\*\*\*\*

\*\*\*\*\*  
**ANALOG DIAGNOSTICS FUNCTIONS**  
 \*\*\*\*\*

Parameter	Symbol	Min	Typ	Max	Units	Notes
<b>Transmitter</b>						
Laser Bias Current Monitor	Bmon+, Bmon-	0		Vcc	V	1
Monitor Photodiode Current Monitor	Pmon+, Pmon-	0		Vcc	V	2
<b>Receiver</b>						
Received Photocurrent	Rpd	0		I	mA	3
Photodiode Responsivity	R	0.5	0.9	1.0	A/W	
Applied Voltage at VpdR pin	Vpd	2.4		Vcc	V	3

- Notes: 1. PIN 17 and 18 provide an analog voltage output proportional to the laser bias current, based on the following formula:  $I_{bias} = V (Bmon+ - Bmon-) / 10 \Omega$ . See below the equivalent circuit.
2. PIN 19 and 20 provide an analog voltage output proportional to the monitor photodiode current, based on the following formula:  $I_{mon} = V (Pmon+ - Pmon-) / 200 \Omega$ . See below the equivalent circuit.
3. PIN 1 is used to monitor the received photocurrent. It must be connected to a positive voltage within the specified above. The received power is given by the photocurrent multiplied by the photodiode responsivity.

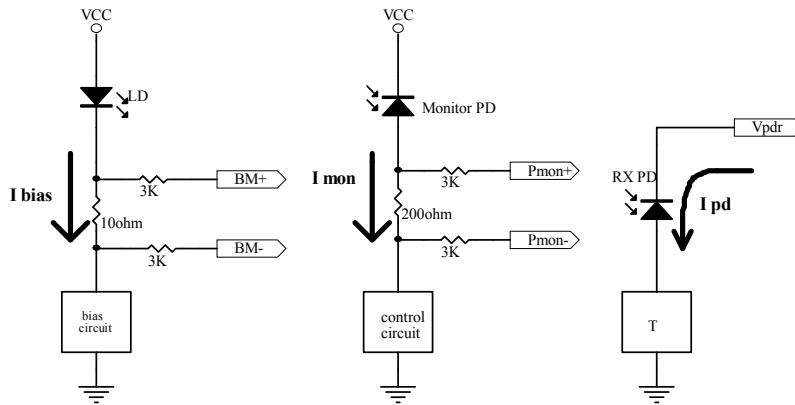

**Analog Monitoring Function Connections**

### CONNECTION DIAGRAM

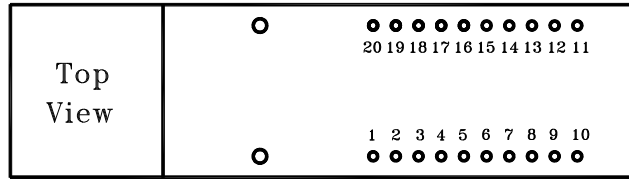

PIN	Symbol	Notes	PIN	Symbol	Notes
1	VpdR	Receiver power monitor. This pin must be connected to a positive power supply (Vcc), preferably via a small resistor. Supplier photocurrent and maybe used to monitor receiver power.	11	VccT	+3.3V dc transmitter power supply
2	VeeR	Receiver ground.	12	VeeT	Transmitter ground.
3	VeeR	Receiver ground.	13	T Dis	Transmitter Disable. Connect this pin to logic "1" to disable module. To enable module connect to logic low "0"
4	NC	No connected	14	TD +	Transmitter Data In
5	NC	No connected	15	TD -	Transmitter Data In Bar
6	VeeR	Receiver ground.	16	VeeT	Transmitter ground.
7	VccR	+3.3V dc receiver power supply	17	Bmon-	Laser Bias Monitoring -- Negative End
8	SD	Signal detect. Logic 1 indicate a normal operation.	18	Bmon+	Laser Bias Monitoring -- Positive End (Bmon+ - Bmon-) = 10 Ω X laser bias current
9	RD-	Receiver Dataout Bar	19	Pmon-	Laser Power Monitoring -- Negative end
10	RD+	Receiver Dataout	20	Pmon+	Laser Power Monitoring -- Positive end (Pmon+ - Pmon-) = 200 Ω X monitor photodiode current
MS	MS	Mounting Studs. Connect to Chassis Ground			

### RECOMMENDED CIRCUIT SCHEMATIC

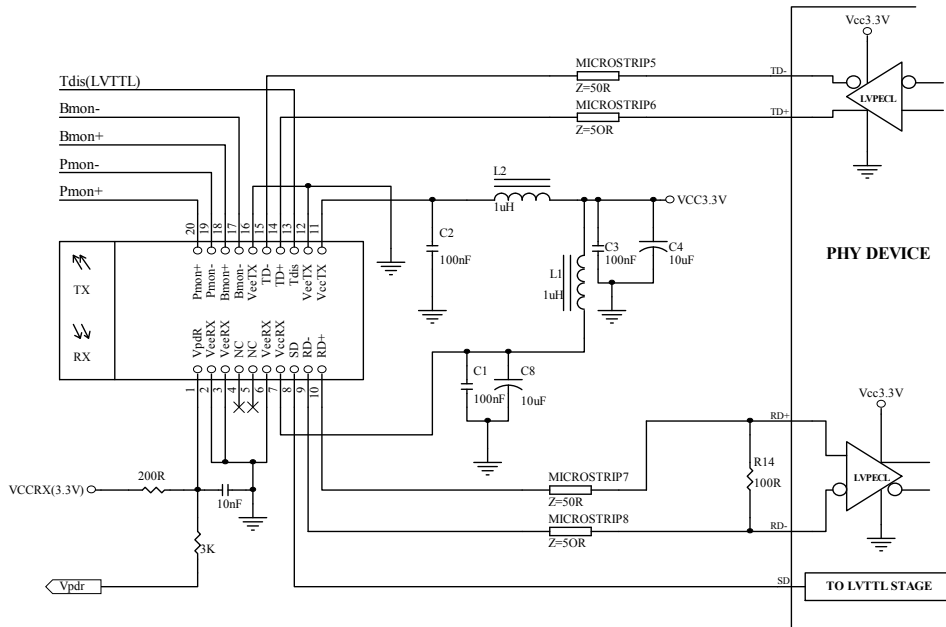

\*\*\*\*\*  
**PACKAGE DIAGRAM**

Units in mm

1) Standard Case

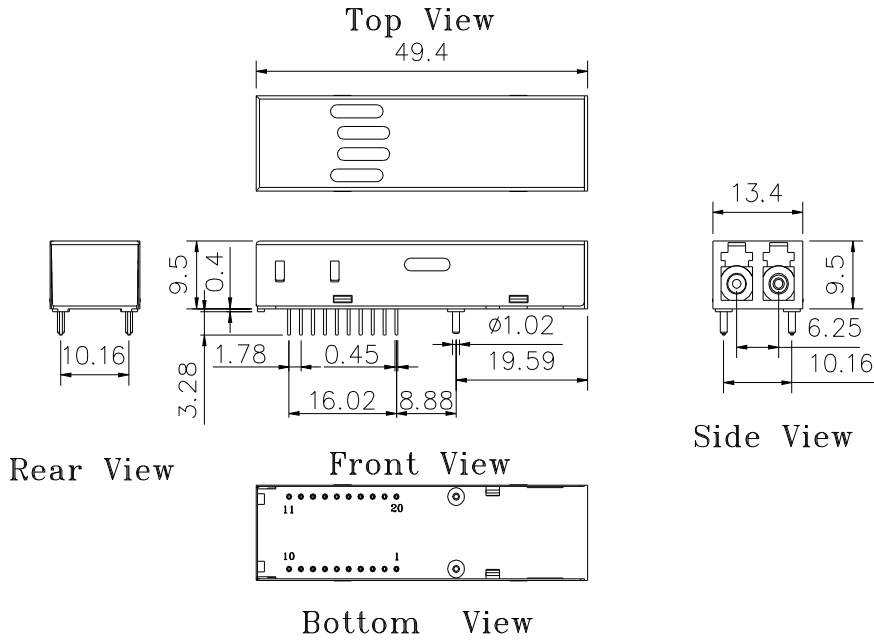

TRSL-9115WG / TRSL-9115AWG

2) Extended Case

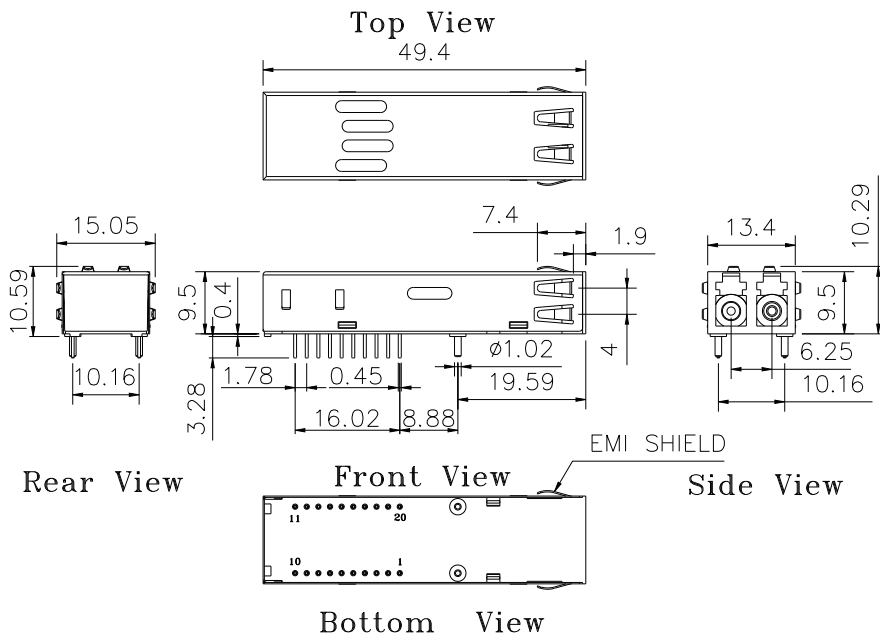

TRSL-9115WEG / TRSL-9115AWEG

**Note:** Specifications subject to change without notice.

\*\*\*\*\*  
**Revision History**

Version	Subject	Release Date
2.0	Initial datasheet	2011/1/1
2.1	Remove Note from the RECOMMENDED CIRCUIT SCHEMATIC	2026/5/8